



User Guide
Barton I-400/I-700 Convertible Chair



Introductory Phase

Review of the I-Series Convertible Chair

1. Capabilities of the I-Series Convertible Chair

- Designed for daily institutional use
- 400 or 700 pound capacity
- Can be used for patients with varying degrees of ability
- Chair can be placed in numerous positions to achieve desired patient comfort level (reduce fatigue)
- Easy to operate Activator Levers (Recline/Tilt)
- Adjustable head and lower body support
- Easy to use Lateral Transfer System

2. Identify and demonstrate parts/features of the I-Series Convertible Chair

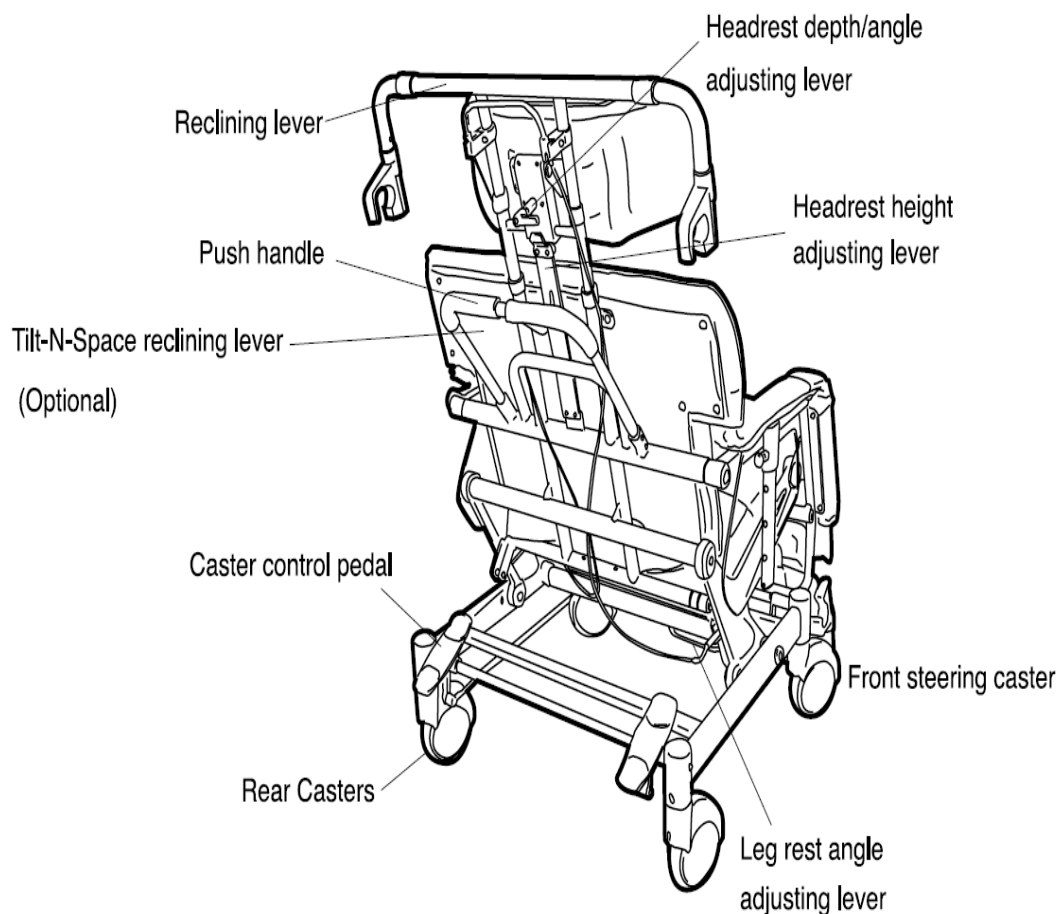

- Adjustable headrest – height, depth, and side support
- Adjustable armrest - height
- Adjustable leg rest – independent adjustment of height and length
- Four wheel brake system – simple foot pedal operation
- Recline/Tilt-n-Space feature – articulate chair through cycle
- Stretcher position – chair easily converts to flat position
- Trendelenberg position – tilt chair then fully recline to place in trendelenberg position

Recline

1. To recline chair engage recline activator and press downward (note pictogram).
2. Can be reclined into a stretcher position.

Tilt

1. To tilt chair engage tilt activator and press downward (note pictogram).
2. Tilt feature locks chair in position maintaining a fixed hip angle while completely redistributing patient's weight (frequent weight redistribution enhances comfort, reduces fatigue, and greatly decreases the opportunity for pressure wounds to occur).
3. By engaging the tilt and recline features, the chair can be placed in the trendelenburg position (take the tilt off before you recline – if you only want stretcher position).
4. **Tilt feature is not counterbalanced and will require health care provider to support more weight.**

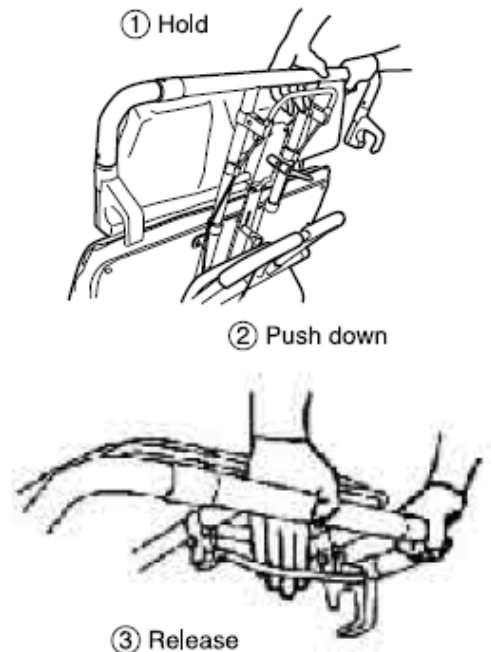

Independent Leg Rest Adjustment



Length Extension



Height Adjustment

1. To lengthen leg rest of chair give the knob under the calf pad a quarter turn.
2. Legs and leg rest must be supported during adjustment.
3. To prevent patient discomfort or potential mishaps health care providers should observe the following;
 - Properly adjust foot rest prior to repositioning patient
 - Before raising patient from flat to an upright position the leg rest should be properly adjusted and foot rest should be lowered into position (this will prevent patient from sliding down chair)

Headrest Adjustments

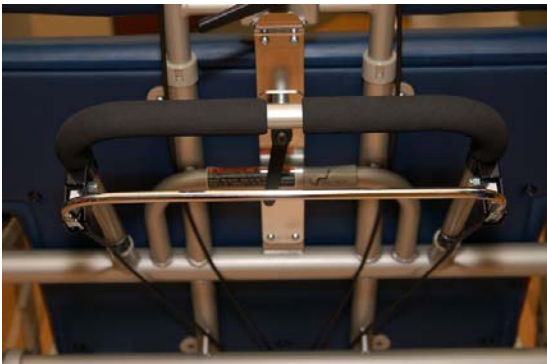

Height Adjustment



Depth/Angle Adjustment

1. Height, depth, and angle of headrest can be adjusted providing many fitting options.
 - The headrest adjustment levers can be loosened with a simple quarter turn to loosen and perform adjustment.
 - The lever is tightened locking the headrest in place by turning the lever in the other direction (approximate ¼ turn).
2. Adjust the headrest height for the students.

Armrest/Side Rail Adjustment

1. Arm rest release knob is located on the support bar underside the armrest.



Using the Brakes

1. Four wheel braking/steering system (with health care provider standing behind chair).
 - All Wheel Lock - press foot plate towards rear of chair.
 - Free Wheel Mode – foot plate is set level with floor (allowing independent movement of wheels).
 - Steering Mode – press foot plate towards front of chair (locks front wheels in place allowing chair to be steered easily).

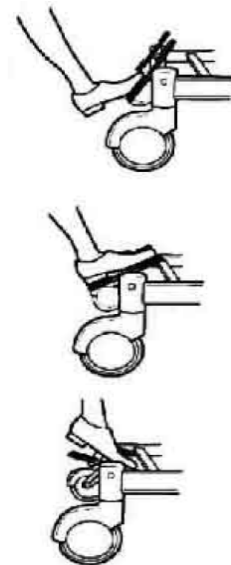

Review of the Lateral Transfer System

Identify parts of the Lateral Transfer System

- Transfer Bar
- Transfer Bar Clamps
- Transfer Bar Straps
- Transfer Sheets
- I-400 or I-700 Convertible Chair



1. Conducting a patient transfer;

- Seek assistance (for safety reasons it is recommended that more than one care giver be available when performing all patient lifts and transfers).
- Prep for lateral transfer
 - a. Fold transfer sheets (neat 6-8 inch folds facilitate placement)
 - b. Place bed or chair at a good working height
 - c. Slide folded transfer sheets under patients head
 - d. Anchor upper hand to mattress top
 - e. Slide lower hand under sheets grabbing folds
 - f. Pull sheets using quick and straight movement in unison.

2. Remove straps from backpack and apply proper number to Transfer Sheet (proper placement of straps is important - feet, hips, waist, shoulder/head).

- The two inch piece of hook Velcro serves as a reference point and is placed face down at the sheet handle, creating a tab. Attach remainder of straps to transfer sheet in same manner.

3. Bring chair alongside bed and place in flat position - line seat of chair up with patient's trunk. Carefully align patient's hip with the middle of chair and insure there is minimal gap between bed and chair.



4. Engage brake of chair.

5. Make sure chair is two inches lower than bed (this insures gravity will aid during the transfer).

6. Rotate brackets into position.

- Brackets are placed in position using a pull and rotate movement.



7. Place transfer bar in brackets with crank end at feet, (press the two silver buttons and walk bar up to other bracket).

- Transfer Bar should be carried with knob end up to prevent handle from releasing and becoming damaged or causing injury.



8. Attach straps to bar via sliding collars on transfer bar (adjust straps so tension is equal).

9. Perform second safety check – brakes, straps, pillow, and therapeutic/monitor lines.

10. Inform patient of nature and intent of procedure and ascertain patient comfort level.

11. Remove transfer handle and set double breaks for lateral transfer.

12. Tips for smooth transfer.

- Keep the transfer handle at right angles.
- Turn handle using a steady rhythmic motion.



13. Disassemble Lateral Transfer System.

- Replace handle.
- Disconnect straps from sheet.
- Remove straps and Transfer Bar.
- Rotate brackets back into storage position.



14. Remove transfer sheet from under patient.

- Reach under patient's ankles and pull sheet on itself (this will prevent shearing of skin).
- Use short controlled pulls to remove sheet (pulling from foot to head at a 45° angle away from body)

15. **Place patient's feet on foot plate before raising patient to a sitting position.**

16. Raise patient to a sitting position.

17. Release brakes, pull chair away from bed.